



## F11 SKIER WEIGHT RECOMMENDATIONS

FREERIDE SERIES		
MODEL	SIZE	WEIGHT (KG / LB)
Gigawatt	195	over 74.8 kg / 165 lb
	185	under 79.4 kg / 175 lb
Megawatt	188	over 74.8 kg / 165 lb
	178	under 79.4 kg / 175 lb
AMPerage	185	over 77.1 kg / 170 lb
	175	68 - 81.6 kg / 150 - 180 lb
	165	under 72.6 kg / 160 lb
Zealot	192	over 81.6 kg / 180 lb
	182	72.6 - 90.7 kg / 160 - 200 lb
Verdict	190	over 81.6 kg / 180 lb
	180	70.3 - 88.5 kg / 155 - 195 lb
	170	under 77.1 kg / 170 lb
Warrant	188	over 77.1 kg / 170 lb
	178	68 - 83.9 kg / 150 - 185 lb
	168	59 - 72.6 kg / 130 - 160 lb

WOMEN'S FREERIDE SERIES		
MODEL	SIZE	WEIGHT (KG / LB)
Element	175	65.8 - 79.4 kg / 145 - 175 lb
	165	under 70.3 kg / 155 lb
Ember	168	65.8 - 79.4 kg / 145 - 175 lb
	158	under 70.3 kg / 155 lb

TOURING SERIES		
MODEL	SIZE	WEIGHT (KG / LB)
Justice	185	over 74.8 kg / 165 lb
	175	under 79.4 kg / 175 lb
Drift	186	over 77.1 kg / 170 lb
	176	68 - 81.6 kg / 150 - 180 lb
	166	under 72.6 kg / 160 lb
Aspect	186	over 77.1 kg / 170 lb
	176	68 - 83.9 kg / 150 - 185 lb
	166	59 - 72.6 kg / 130 - 160 lb
	156	under 63.5 kg / 140 lb
Stigma	176	68 - 86.1 kg / 150 - 190 lb
	168	59 - 72.6 kg / 130 - 160 lb
	160	under 63.5 kg / 140 lb
Guru	176	68 - 86.1 kg / 150 - 190 lb
	167	59 - 72.6 kg / 130 - 160 lb
	158	under 63.5 kg / 140 lb

WOMEN'S TOURING SERIES		
MODEL	SIZE	WEIGHT (KG / LB)
Starlet	176	over 68 kg / 150 lb
	166	59 - 72.6 kg / 130 - 160 lb
	156	under 63.5 kg / 140 lb
Syncra	168	65.8 - 79.4 kg / 145 - 175 lb
	160	59 - 70.3 kg / 130 - 155 lb
	152	under 63.5 kg / 140 lb

## TUNING SPECS

SANDWICH CONSTRUCTION

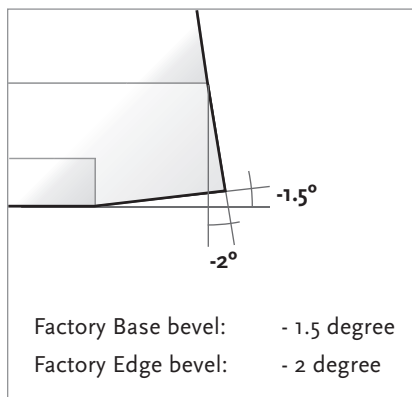

TORSION BOX CAP CONSTRUCTION

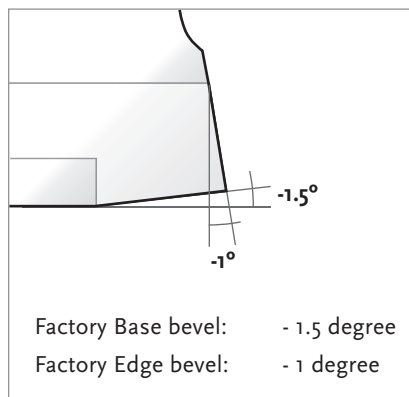

Detune tips and tails to personal preference. We recommend feathering edges 3-4 cm past contact points.





## 2011 SKI MOUNTING SPECS

Measurements taken from tail, in millimeters:

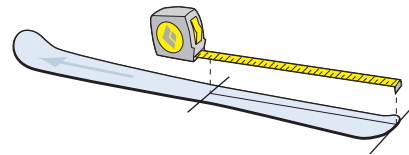

MODEL	SIZE	TELE: PIN LINE (mm)			ALPINE: MID-BOOT (mm)
		25.5 and smaller boot	26.0 to 27.5 boot	28.0 and larger boot	All Boot Sizes
Gigawatt*	195	994	999	1004	874
	185	949	954	959	829
Megawatt*	188	928	933	938	808
	178	885	890	895	765
AMPerage / Element*	185	949	954	959	829
	175	904	909	914	784
	165	859	864	869	739
Zealot*	192	968	973	978	848
	182	940	945	950	820
Verdict	190	956	961	966	836
	180	912	917	922	792
	170	868	873	878	748
Warrant / Ember	188	937	942	947	817
	178	894	899	904	774
	168	850	855	860	730
	158	807	812	817	687
Justice	185	960	965	970	850
	175	898	903	908	776
Drift /Starlet	186	937	942	947	817
	176	893	898	903	773
	166	849	854	859	729
	156	805	810	815	685
Aspect	186	926	931	936	806
	176	882	887	892	762
	166	838	843	848	718
	156	795	800	805	675
Stigma / Syncra	176	857	862	867	737
	168	823	828	833	703
	160	789	794	799	669
	152	757	762	767	637
Guru	176	869	874	879	749
	167	827	832	837	707
	158	790	795	800	670



Use 3.6 Ø x 9.5mm drill bit for non-metal skis. For metal, use 4.1 Ø x 9.5mm and tap for metal skis. Also cross reference with binding manufacturer's screw recommendation, if any. For alpine and AT, we recommend using white wood glue as a sealant. **For tele, for maximum screw retention, we recommend 1-hour epoxy.**

Please read and know proper telemark mounting best practices. Among many guidelines, these include using a mandatory **8-10 Nm** screw torque with **1-hour epoxy**. Alpine binding screw mounting torques are not enough for telemark binding forces. Any less torque than 8-10 Nm does not create enough clamping force to overcome upward binding force. As a result, your screws can loosen, resulting in the binding ripping out.

\*Reference the forward mounting recommendations on the next page for alternative positions.



## 2011 SKI MOUNTING SPECS

### MEASURE

It's important that you accurately determine your mounting location based on the recommended specifications (see chart on the Mounting Specs page) with personal preference adjustments, if applicable or known. Measure twice, drill once.

**Alpine:** For AT or alpine mid-boot, the ski is marked with our recommendation. We list in our specs what the exact location of this mark is on the ski, so be sure to double-check tolerances as it can shift by a few mm's. We don't recommend moving the mount location backward from here, but it's personal preference if you want to mount select skis forward. See our recommendations for forward mounting on this page.

**Tele:** Again, things get complicated with tele. If you base all things off of the chord-center (or some reference point along those lines), different boot sole lengths will affect the mounting position and its relationship to the sidecut and overall length. In the BD mounting chart you'll see that we break it down into three overall shell sizes and give recommendations based on that. The middle 26-27.5 is the baseline, shift 5 mm forward for 28.0 and up, and 5 mm backward for 25.5 and smaller. This keeps a good relationship between balance point of the ski and, most importantly, mid-boot in relation to the center of the sidecut. On BD boots we have that mid-boot marked on the shell itself to keep this easy, which is based on the distance from pin-line to heel. When in doubt, trust that lining up this mark with the mid-boot mark on the ski is your best option, as modern designs have thrown the old standard rules of thumb out the window.

### \*FORWARD MOUNTING

Binding mount position dramatically affects your ski's performance characteristics. We spend quite a bit of time dialing in this location for each model and for each length of ski. During development, our test skis end up looking like Swiss cheese from all the mount holes. The relationship between radius arc center, running length, and balance of stiffness all play into this decision.

That said, we recognize that personal preference also plays an important role. You know your tastes and skiing style, and if you prefer a more centered stance for a more playful feel, the following skis have excellent alternative mounts forward of the recommended boot midsole mark.

#### **Gigawatt: Up to +3 cm**

BD athlete Zack Griffin goes large at +3 cm. We'd recommend no more than +2 cm, but he seems to make it work.

#### **Megawatt: Up to +2.5 cm**

With the 2011 Megawatt's stiffer tip, you can really stomp on the nose and trust it. Getting more centered on this ski gives it a more playful twist. If you're using it as an everyday ski and want to arc on hard pack, mount at +2.5 cm. If you want a more classic powder ski feel, stick with the recommended position.

#### **Zealot: +1.5 to +2 cm (182 cm only)**

If you're interested in the playfulness of the AMPerage, but want the dampness and power of a metal laminate GS ski at times, shift the mounting point of the 182 cm Zealot forward between 1.5 cm to 2 cm, max. Ski the 192 cm length on the recommended mounting point—it's just plain old built for speed and power. The tail is less rockered than the 182 cm version, so the mounting point is already more centered in relation. Don't mess with it.

#### **AMPerage: +2.5 cm**

The AMPerage can be safely mounted up to +2.5 cm before you start washing out your tails. However, BD athletes Johnny Collinson and Calum Pettit say to go with +3 cm. If you're of their likes, we can't argue with them.

## MOUNTING TIPS

"Standard protocol" varies from shop to shop, so here, in detail, is what we feel makes for a solid binding mount.

### PRECISION

This is paramount for telemark bindings, which have much higher peak loads than an alpine or AT binding. What is often overlooked is that the ISO standard minimum for binding pull-out strength for alpine skis is 292 pounds per screw, which is fine for alpine binding systems but is not nearly enough for an active tele binding. Our pullout strength exceeds 440 pounds per screw, but that pullout strength is only achieved with a precision mount. For example, that strength drops 40% if the screw doesn't thread in straight. How many times have you chased a screw hole that wasn't completely in line with the binding and you just kind of forced it in, cocked over, until it snugged down straight? That's a major no-no.

### TORQUE SPECS

Most alpine specs have around 4-5 Nm per screw when you are using a TLD (torque limiting device). For an active tele binding you need upwards of 8-10 Nm. Some company's skis may not take this much, but for BD skis, feel free to crank it down this much (in fact you must on bindings such as the O1.) In addition, we recommend a 3.6 Ø drill bit to get the best thread retention based on the minor diameter of the screw. This tighter screw fit also mandates a higher torque to get the screw into the ski, so again, the traditional TLD setting probably would not seat the screw tightly enough.



## MOUNTING TIPS

### WITCHCRAFT

With tele there's a bit of witchcraft at every corner. All bindings are not the same and in fact have drastically different forces associated with each. The boot size and skiing style greatly influence the degree of mounting sloppiness that can be tolerated. In addition, the screws, screw heads and shapes are different, and the industry lacks any sort of standard or unification, resulting in very specific mounting issues. For example: The tapered-head screws provided with K2's older inserts work fine with BD bindings except for the O3, which requires a flat-head screw that interfaces with the plastic. We supply a substitute screw (See Black Diamond Spare Parts Manual) to be used with the O3 binding and K2 inserts. For the O2 and O1, the screw interfaces with a tapered stainless steel or aluminum section, and the K2 screw is fine but can require periodic tightening.

### CLEANLINESS

Be sure to remove any dust or shards from the drilled hole. It is important to use clean screws, without any chunks of material embedded from a previous mount. A screw with smooth threads ensures proper thread cutting when you turn the screw in. It is also important to apply adequate downward pressure when starting the screw so the threads cut immediately and don't spin and grind away the first engagement. Tapping the hole first is never a bad practice regardless of metal or not. When mounting thinner skis that require the screws to be ground down shorter, be extra careful to grind a slight taper and to avoid leaving any sharp burrs which will not cut a smooth thread into the ski.

### EPOXY

We recommend using epoxy for all telemark mounts. Epoxy can increase your overall maximum pullout strength, but most importantly acts as a buffer to decrease screw-loosening possibilities. This in turn can lead to a degradation of the ski's core and increase peak shock loads that will eventually result in the binding ripping out of the ski. For alpine and alpine touring bindings, if you don't prefer epoxy, use simple wood glue to seal the hole and lubricate the screw as it is being twisted in to help achieve suitable clamping force for given torque values.

### O1 BINDING SCREW TORQUE VS. CLAMPING FORCE

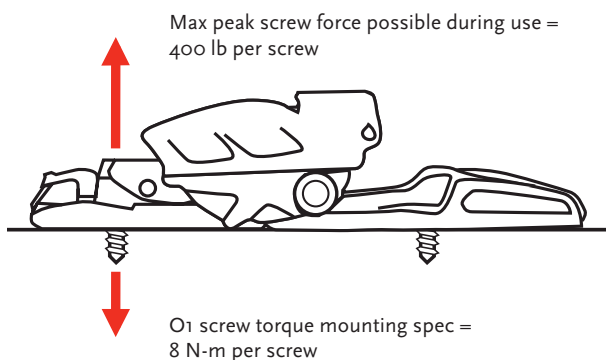

When binding force peaks above clamping force screws can loosen:

- ♦ Example (as shown in bottom left diagram): If torqued only to 5 Nm then clamp force only equals 275 lb. When torqued to 6.75 Nm you get the minimum 400 lb of clamping force.
- ♦ Any loosening creates a shock loading scenario and risk of pull out increases significantly.
- ♦ Torque Screws to 8 Nm and always use epoxy!
- ♦ **Note:** 8 N-m is way more than you think!

BINDING SCREW INSTALLATION TORQUE VS. CLAMPING FORCE

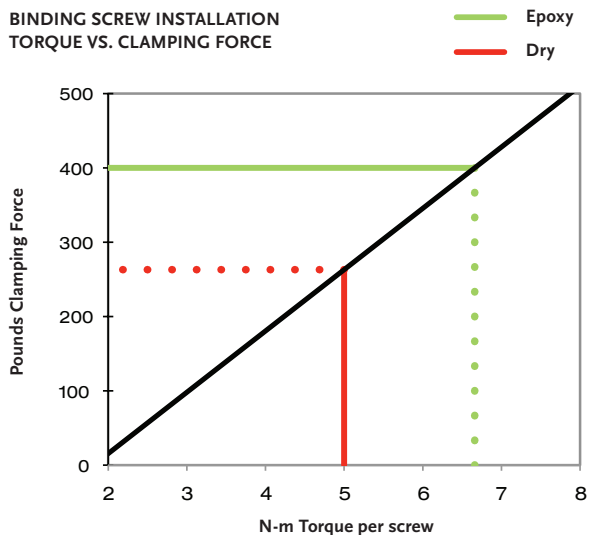

EPOXY VS. NO EPOXY

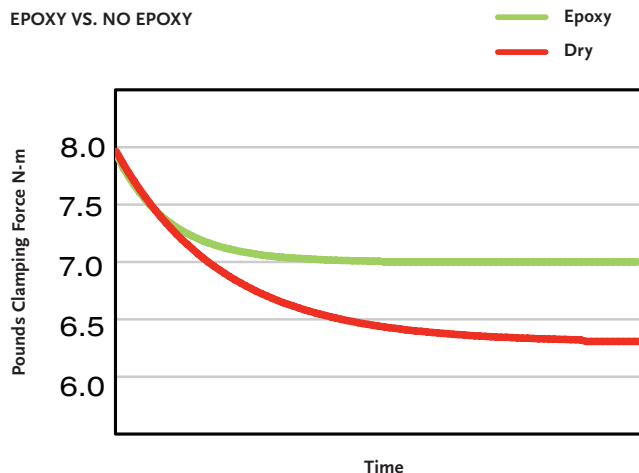



## **MOUNTING TIPS**

### **JIGS**

The BD Jig is a great tool for precision tele mounts and keeping the heel block in the prescribed location every time or if you don't have the actual boot to work with. (Sorry if you normally mount skis with the tips facing left. Perhaps you can stand on your head or mount behind your back, Jimi style.) Fully support the ski so that when applying drilling force you don't flex the ski; this is crucial because it ensures that the holes are perpendicular. Some non-BD skis can get quite thin, so make sure your drill bit and provided screws are not going to dimple the base, especially at the heel block areas. Be careful on the Fritschi jig in case you have to pull the clamp boots off for maximum width, as well as making sure you have all four arms with the boots facing the correct direction. We highly discourage any type of paper template mount as you will never achieve full strength and can also compromise the overall strength of your binding.

### **HOLES AND SCREWS**

For Fritschi AT and BD tele bindings, 3.6 Ø x 9.5 mm is the recommended drill bit and depth for our skis. However, each ski manufacturer has a recommended hole diameter and each binding screw design should have a specific hole diameter recommendation. Confused about which to use? Put down the drill and contact the manufacturer. If all else fails, use the binding recommendation and tap the hole.

As a rule of thumb, the more expected force on the system, the higher torque the screws are going to need to resist the resulting binding force acting against it. When that relationship is out of whack, the screws can begin to loosen and even a single loose thread will dramatically affect pullout strength. It can also slowly degrade core-retaining properties by slight movements of the screw over time, again reducing pullout strength.

Using torque limiting power drills is usually a bad idea unless you're skilled in the art. We recommend hand tightening each screw with a TLD-enabled hand posi-driver, making sure that each screw goes directly and perpendicularly in and then doing a final torque spec twist on each screw. If for some reason you don't have a TLD and are working on BD skis and bindings, hand tighten more than you think—pushing down with all your strength while turning the screw means that you're probably at around 10 Nm, which is fine for BD's O1 binding or skis.

### **RECAP OF THINGS NOT TO DO:**

- Don't re-use old screws that have crap plugged in the threads. When you screw that into a new ski you are cutting crappy threads into the core and compromising strength.
- If you need to grind screws for some reason (e.g., the ski is thinner than the screw design provided), be extremely careful not to leave any burrs—these will mess with the thread cutting of the ski core.
- If you get a spinner and strip a hole, don't half-ass it—fix it right by putting a heli-coil in.
- Don't reverse bend the ski when applying drilling pressure. Support it from beneath so that the screw hole is perpendicular to the ski. Even a small amount of flex will change the angle and you'll lose full pullout strength potential.
- Don't grind out your initial hole threads by carelessly spinning the screw without downward applied force.

## **WAXING AND STORAGE TIPS**

As with any ski, frequent waxing helps prolong base longevity. During long-term storage (i.e., the off-season), leaving a thick coat of wax on the base will help prevent oxidation.

