



CWR450DZ

Built in Wine Cellar

Owner's Manual

This owner's manual provides instructions on safe installation, use, and maintenance. Please read it carefully and save it for reference.



<http://www.edgestar.com>

Table of Contents

Important Safeguards.....	2
Specifications.....	3
Parts and Features.....	4
Installation.....	5
Operation.....	5
Temperature Control.....	6
Rack Removal and Insertion.....	7
Troubleshooting.....	8
Limited Warranty.....	10

First Time Operating Instructions

Before use, make sure all packaging labels and materials are removed from the unit. Be sure to keep track of all included parts and pieces before discarding packaging materials. It is advised that you keep the original box and packing materials in case you are ever to move or ship the unit in the future.

Let the unit stand for at least 24 hours before use; this allows the cooling components to settle from transit. The instruction manual should be thoroughly read before use.

IMPORTANT SAFEGUARDS

When using an electrical appliance, basic precautions should always be followed, including the following:

BEFORE USE, PLEASE READ AND FOLLOW ALL INSTRUCTIONS FOR THIS WINE COOLER

- Do not use if the power supply cord is damaged. If damaged, it must be replaced by the manufacturer or a similarly qualified person.
- This wine cooler is not intended for use by young children without supervision. Young children must be supervised to ensure they do not play with the appliance.
- Ensure the cooler is unplugged before cleaning or if not in use.
- To clean the cooler use only mild detergents or glass cleaning products. Never use harsh detergents or solvents.
- It is not recommended to use this wine cooler with an extension cord or power strip. Please ensure that the appliance is plugged directly into the electrical outlet.
- When positioning the wine cooler, ensure that there is at least a 2" clearance at the sides and a 4" clearance at the back of the cooler. This will allow for adequate ventilation of heat from the back of the cooler.
- This cooler is designed to store wine bottles. If food is placed inside, ensure that there is sufficient airflow between items. Also note that the temperature range for this cooler is optimized for wine and beverage storage. Perishable food items may require a different storage environment.
- Do not place hot food or drinks into the wine cooler before they cool down to room temperature.
- Close the cooler door immediately after putting in any items so the inside temperature will not rise dramatically.
- Avoid subjecting the cooler to external heat sources or direct sunlight.
- For a stable installation, make sure the cooler is placed on a flat, level, and solid surface.
- Make sure that the surface on which the wine cooler is placed is strong enough to hold the wine cooler once it is fully loaded with wine bottles.
- Do not place any other appliances on top of the wine cooler.
- The wine cooler is an electrical appliance. To avoid injury or death from electrical shock, do not operate the wine cooler with wet hands, while standing on a wet surface, or while standing in water.
- Do not use outdoors or in wet or moist conditions.
- Do not turn the cooler upside down, on its side, or 45° or more off level.
- Never pull the power cord to disconnect it from the outlet. Grasp the plug and pull it from the outlet.
- Never lift or carry the wine cooler by the power cord.
- Keep the power cord away from heated surfaces.
- This wine cooler is designed for household, non-commercial use only.
- Do not plug this cooler into the power socket before set up is completed.

- An empty cooler can be dangerous for children. If disposing of the cooler remove gaskets, latches, lids and the entire door from your unused appliance, or take other action to ensure that children cannot become trapped inside.
- If your model of wine cooler is equipped with a lock, take care to keep the keys away from children.
- Do not cut or remove the third prong (the grounding prong) from the power cord.
- The cord should be secured behind the unit and should not be left exposed or dangling.
- Do not move this cooler without emptying it of its contents and securing the door in a closed position.

1. Specifications

Model Number	CWR450DZ
Capacity	45 bottles
Input Power	140W
Rated Frequency	60Hz
Power Consumption	1.2kw.h/24h
Cooling System	R134a
Ambient Temp	86.5°F
Temperature Range	45 ~ 65°F
Rated Voltage	115V
Weight	147 Lbs
Dimensions (HxWxD)	34 3/4"x23 7/8"x22"

2. Parts and Features

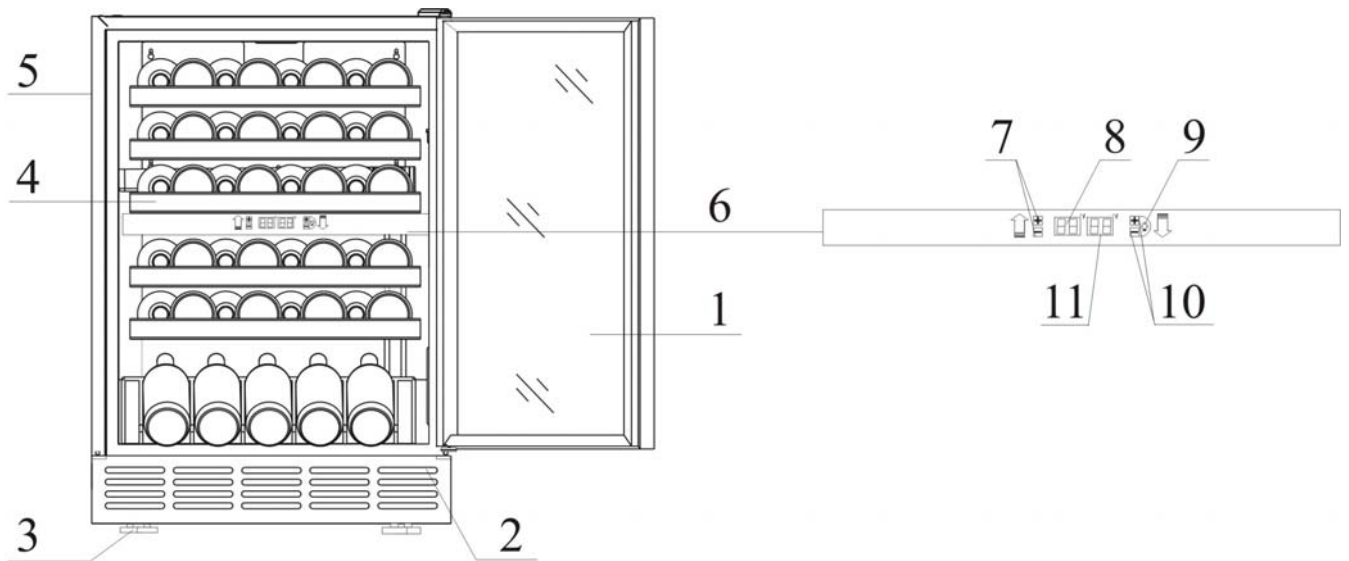

Important Note: Even if your refrigerator looks slightly different; the operation will essentially be the same. Picture is provided for reference.

- 1 Dual-pane window
- 2 Front grill
- 3 Adjustable legs
- 4 Main shelving
- 5 Cabinet
- 6 PCB Cover
- 7 Temp. adjustment (upper shelves)
- 8 LED display (upper shelves)
- 9 Light button
- 10 Temp. adjustment (lower shelves)
- 11 LED display (lower shelves)

3. Installation

- Remove all exterior and interior packaging materials before use.
- Check that you have all parts and copy of instruction manual.
- Place your wine cooler on a flat, dry surface, strong enough to support the unit when fully loaded.
- The unit is designed to be built-in (recessed) or free standing.
- Do not place heavy objects on top of the unit.
- The unit is not designed for installation in a garage or basement.
- Do not place in direct sunlight or near sources of heat. Extreme hot and cold temperatures may cause the unit to perform improperly, increase electrical consumption, or cause damage.
- Do not place next to a major appliance that emits large amounts of heat. (Such as ovens, microwaves, dishwashers, etc.)
- Do not share unit with the same outlet as a refrigerator or microwave.
- Before connecting to the power source, let the unit stand upright for approximately 24 hours. This will reduce the possibility of a malfunction in the cooling system from handling during shipping and transportation.
- Gently clean the unit's interior surface with warm water, using a soft cloth before first use.

4. Operation

1. Carefully slide the racks in the wine cellar.
2. Determine the best temperature setting to use for your wine.
3. Place bottles gently inside cooler.
4. Plug the power cord into a standard grounded electrical outlet.
5. Keep door closed to conserve energy and maintain proper storage temperature.
6. You can turn the interior light on and off by pressing the 'Light' button on the front control panel of the unit.
7. If unit is equipped with a lock, insert provided key and turn to operate.

Important Note: When using the unit for the first time, allow at least 24 hours for the internal temperature to become adjusted properly. Also make sure there are at least three to five bottles in the unit.

5. Temperature Control

Preset temperature control:

This unit is factory programmed at 'storing' temperature. The manufacturer presets the temperature for the upper three shelves (white wines) at **48°F (9°C)**. The red wines are stored on the lower three shelves, where the temperature is preset at **56°F (13°C)**.

Manual temperature control:

To manually adjust temperature, press the (-) button on the control panel to decrease, and the (+) button to increase by **1** degree inside the unit. The upper three shelves (white wines) have a range from **45°F (7°C)** to **54°F (12°C)**, and the lower (red wines) have a range of **54°F (12°C)** to **65°F (18°C)**.

When the temperature of the unit becomes too low, the LED will display "LL", likewise, when the temperature is too high, it will display "HH". The unit will display "ER" in the event of an error or power disruption.

Important Note: This unit will operate best in a room with a temperature of less than **90°F (32°C)**.

6. Wine Rack Removal and Installation

Important Note: Make sure the door is completely open before removing racks to avoid damage.

1. Remove any stored bottles.
2. Pull the racks out horizontally and press the button in on each side. (Fig. 1)

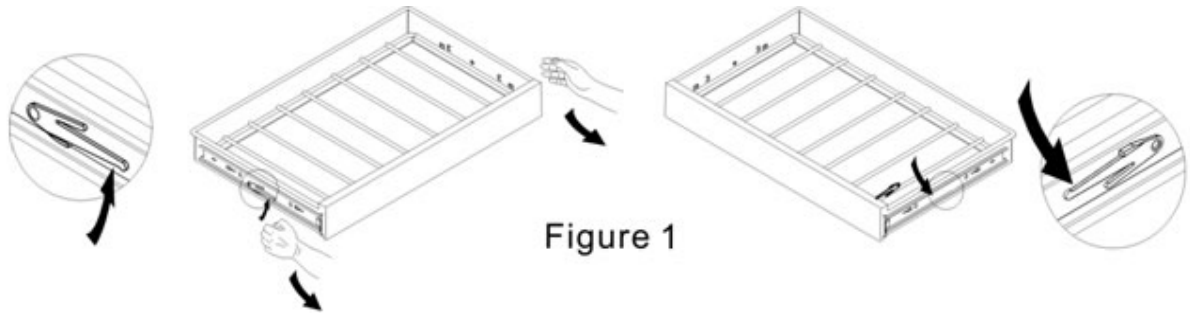

3. Push the racks into sliders. (Fig. 2)

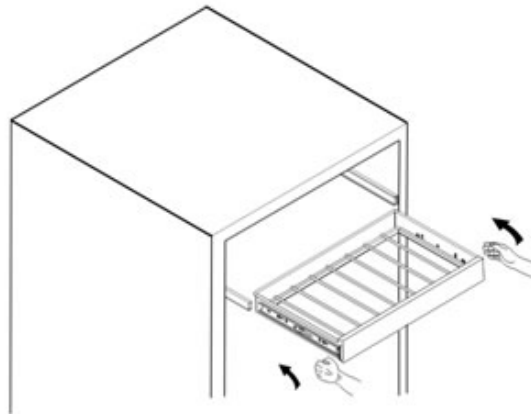

Important Note: The bottom rack cannot be removed.

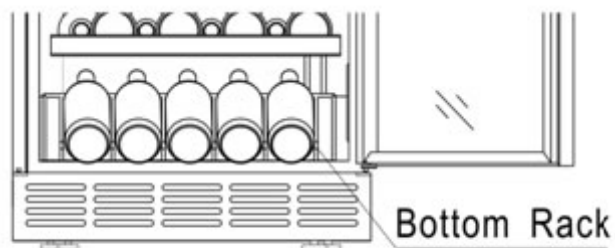

Figure 3

7. Troubleshooting

Symptoms	Possible causes	Solutions
<p>The wine cooler does not turn on.</p>	<p>There is a power failure.</p> <p>The cooler is not plugged in.</p> <p>A house fuse has blown or the circuit breaker is tripped.</p>	<p>Ensure the cooler is plugged in and the power outlet has power.</p> <p>Replace the broken fuse in your fuse box or reset the breaker.</p>
<p>The wine cooler will not reach the desired temperature</p>	<p>The cooler is placed too close to a heat source.</p> <p>The cooler does not have sufficient ventilation.</p> <p>The door is opened too frequently or for a long period of time.</p>	<p>Keep the cooler away from sunshine or other heat sources.</p> <p>Make sure the wine cooler has several inches of ventilation on the sides and back.</p> <p>Close the door tightly and do not open the door too frequently or for a long period of time.</p>
<p>Frost is forming in the wine cooler</p>	<p>The environment is humid.</p> <p>The ambient temperature is too low.</p> <p>The door is being opened too frequently.</p>	<p>Though the unit uses an "auto-defrost" system, under certain conditions, manual defrosting may be required. If frost builds up, you can try running the cooler on a warmer temperature setting, minimizing the number of times you open the door, or unplugging the unit to allow the frost to melt.</p>

Symptoms	Possible causes	Solutions
<p>The cooler turns on and off frequently.</p>	<p>The room temperature is higher than the recommended ambient temperature (77°F).</p> <p>The door is being opened often.</p> <p>The door is not completely closed.</p> <p>The door gasket is not sealing properly.</p> <p>The cooler does not have the suggested ventilation.</p>	<p>Run the cooler in the appropriate ambient temperature.</p> <p>Minimize the number of times the door is opened.</p> <p>Make sure the door is completely closed.</p> <p>Make sure the door gasket is properly sealing.</p> <p>Make sure the cooler has at least 2" on the sides and 4" in the back for clearance.</p>
<p>The cooler makes too much noise.</p>	<p>If the noise is from the fan, it may be normal operating noise.</p> <p>The unit is not level.</p> <p>Popping or crackling noises are coming from the unit.</p>	<p>The fan will make some noise when operating- this is normal.</p> <p>Make sure the cooler is on a level surface.</p> <p>Some popping or crackling noises are normal. They are caused by expansion and contraction of the inside walls due to temperature changes.</p>
<p>The door will not shut properly.</p>	<p>Your cooler is not level.</p> <p>The door gasket is dirty.</p> <p>The door gasket is malformed.</p> <p>The shelves are incorrectly installed.</p>	<p>Make sure the cooler is on a level surface.</p> <p>Clean the door gasket.</p> <p>Make sure the door gasket is properly sealing.</p> <p>Correctly install the shelves.</p>

8. Limited Warranty

This EdgeStar product is warranted to be free from defective workmanship and materials for the first year following the date of original purchase. Replacement parts will be supplied free of charge for the first year following the date of original purchase. Labor will be performed free of charge for the first 90 days following the date of original purchase.

WHAT IS COVERED:

This warranty applies to the original purchaser only, and only covers defects in workmanship experienced during operation of the product under normal service, maintenance, and usage conditions. This warranty applies to the purchase and use of this product in residential settings within the United States of America.

WHAT IS NOT COVERED:

The following limitations apply to the coverage of this warranty:

- Optional accessories, attachments, and appearance items are excluded from warranty coverage, as is shipping damage, and any damage caused by improper voltage or any other misuse, including abnormal service, handling, or usage.
- This warranty does not cover normal wear and tear on parts or replacement of parts designed to be replaced, e.g. filters, etc.
- This warranty does not cover service trips to deliver, pick-up, repair, or install the product, or to instruct in proper usage of the product.
- Damages or operating problems resulting from abuse, operation outside environmental specifications, uses contrary to instructions provided in the owner's manual, accidents, vermin, fire, flood, improper installation, unauthorized service, acts of God, unauthorized installation or modification, or commercial use are excluded from warranty coverage.
- This warranty does not cover labor incurred 91 days or more after the date of original purchase.
- This warranty does not cover use of EdgeStar products in commercial settings.

DESCRIPTION OF WARRANTY SERVICE:

All defective product components covered by this warranty will be repaired or replaced, at EdgeStar's option, free of charge on a mail-in basis to EdgeStar's authorized repair facility during the first 90 days from the date of original purchase.

All defective product components covered by this warranty will be repaired or replaced, at EdgeStar's option, on a mail-in basis to EdgeStar's authorized repair facility during the time period beginning on the 91st day from the date of

original purchase and ending one year from the date of original purchase. During this time period, parts will be supplied free of charge, but labor charges will apply. All replacement parts and units will be new, remanufactured, or refurbished. All products and components replaced by EdgeStar under warranty service become the property of EdgeStar.

OBTAINING WARRANTY SERVICE:

Contact EdgeStar for troubleshooting assistance and warranty service authorization at 1-866-319-5473. Please have your order receipt available to confirm the date of purchase. Once an EdgeStar authorized representative has confirmed that your product is eligible for warranty service, the product must be returned to an EdgeStar authorized repair facility. The purchaser is solely responsible for prepaying all shipping related costs to and from the repair facility. EdgeStar is not responsible for damage resulting from shipper mishandling or improper packaging.

Do not return defective product to the place of purchase.

THIS WARRANTY IS IN LIEU OF ANY OTHER WARRANTY, EXPRESS OR IMPLIED, INCLUDING WITHOUT LIMITATION, ANY WARRANTY OF MERCHANTABILITY OR FITNESS FOR A PARTICULAR PURPOSE. TO THE EXTENT ANY IMPLIED WARRANTY IS REQUIRED BY LAW, IT IS LIMITED IN DURATION TO THE EXPRESS WARRANTY PERIOD ABOVE. NEITHER THE MANUFACTURER NOR ITS DISTRIBUTORS SHALL BE LIABLE FOR ANY INCIDENTAL, CONSEQUENTIAL, INDIRECT, SPECIAL, OR PUNITIVE DAMAGES OF ANY NATURE, INCLUDING WITHOUT LIMITATION, LOST REVENUES OR PROFITS, OR ANY OTHER DAMAGE WHETHER BASED IN CONTRACT, TORT, OR OTHERWISE. SOME STATES DO NOT ALLOW THE EXCLUSION OF INCIDENTAL OR CONSEQUENTIAL DAMAGES, SO THE ABOVE EXCLUSION MAY NOT APPLY TO YOU. THIS WARRANTY GIVES YOU SPECIFIC LEGAL RIGHTS. YOU MAY HAVE OTHER RIGHTS THAT VARY FROM STATE TO STATE.

