

Compost Tumbler

A smart design and high-quality materials make this new Compost Tumbler both effective and easy to use. The large fill door opens wide for loading and emptying. The black color and extra thick walls retain heat to help keep the materials inside cooking.

Handholds make it easy to turn the drum every few days. The Compost Tumbler is molded from 100% recycled, UV-inhibited plastic, holds 6½ cu. ft. (5 bushels) and will produce compost for many years to come!

Frame Assembly

Tools needed:

Adjustable wrench
Flathead screwdriver or pliers

Parts and Hardware included:

Composter Body
Composter Door
2 Long Axle Bolts
6 Frame Bolts
8 Self-locking Nuts
Axle Hub
Steel Axle
2 Shoulder Frames (A)
2 Leg Frames (left) (B)
2 Leg Frames (right) (C)

Step 1. Join all Leg Frames and line up the pre-drilled holes on the end of each frame (see Diagram). Do not secure the frames with bolts until Step 3. If the holes do not align correctly, you may simply need to reverse the position of the Leg Frames.

Step 2. Join the Shoulder Frames (A) with the Left and Right Leg Frames (C, B) on each side. Line up the pre-drilled holes where the frames meet.

Step 3. Thread a short Frame bolt through each of the 6 predrilled holes, with the head of each bolt facing out. Use an adjustable wrench or pliers to hold the nut while you use the screwdriver to tighten the bolts.

Mounting Assembly

Step 4. Make sure that the frame is resting on a flat and level surface. Place the ends of the Axle Hub through the holes inside the composter as shown. The Axle Hub is flexible so you can bend it to fit it into place.

Step 5. Slide the Steel Axle through the Hub. The Bolt holes in the Axle should be visible on both sides of the composter.

Step 6. Insert a Long Axle Bolt through the hole in each end of the Axle. The Axle Bolt holes are not perfectly aligned. This is to ensure that when the bolts are positioned in the holes, they will angle out and away from the body of the composter. If the Bolts are not angled outward when placed in the Axle holes, remove the bolts and rotate the Axle to change the hole alignment and re-insert the Bolts.

Step 7. With a second person to help, carefully lift the composter and rest it on the frame, directing the

Over, please

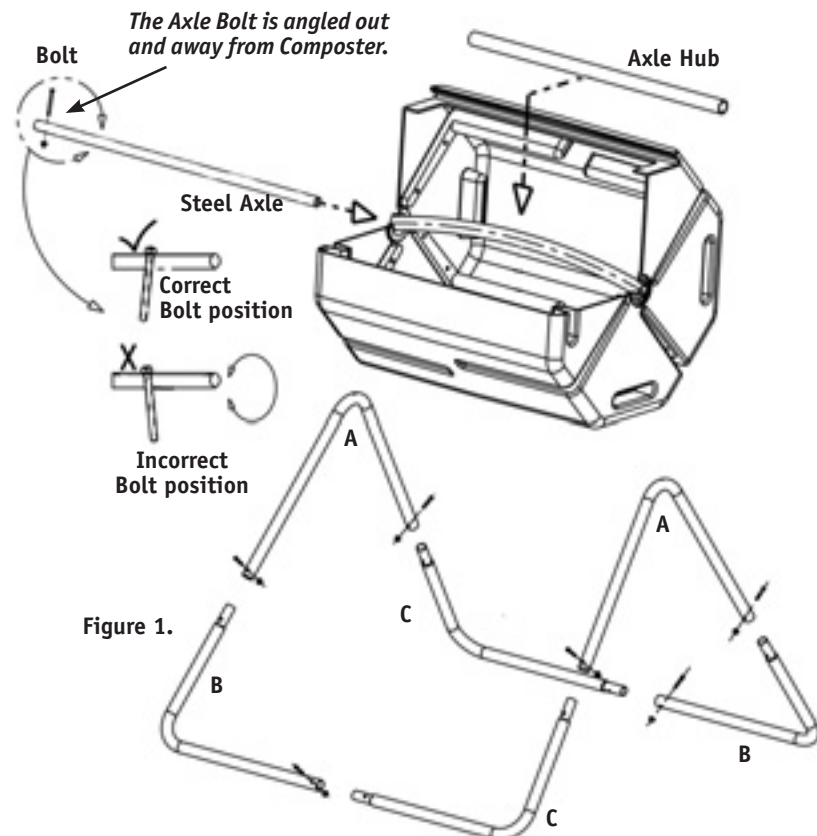

bolts into the pre-drilled holes in the top of each Shoulder Frame (Figure. 2). Tighten a nut onto each bolt from underneath. Check that all nuts are fully tightened on the composter and that the composter rotates freely.

Step 7. Slide the Door into place (Figure 2). When the composter is empty, the weight of the door will make it rotate to the bottom of the composter. As you add material to the composter, the door will rotate to the top. The assembly is now complete and your composter is ready to use.

Batch Composting

The Compost Tumbler is a batch composter as opposed to a continuous composter. This means that you collect materials separately and then fill up the Compost Tumbler all at once. Making a batch of compost is like making a batch of chocolate chip cookies; instead of adding small quantities of materials every day, you put everything together at once to make one big batch. You will probably need to stockpile materials until you have enough for each batch. Do not add new material until the batch has finished cooking and the finished compost has been removed.

As you begin gathering materials for composting, remember that shredded materials decompose faster. You can do this with a gas or electric-powered shredder, or simply run a lawn mower over the material and then rake it up.

Adding an activator, such as our Super Hot Compost Starter, will also help break down leaves. Super Hot is a two-part system of energizer (high nitrogen-enriched peanut meal) and activator (alfalfa, microorganisms, cocoa meal, and other ingredients). With the right blend of shredded ingredients and some practice you can make compost in just 4 to 8 weeks.

Loading Your Composter

1. Once you have gathered about 5 bushels of composting materials, we recommend mixing together 1/2 bag of the Super Hot energizer with 1/2 bag of the Super Hot activator and set aside. The bags do not contain the same volume of material, so your mixture will be approximately a 2:1 ratio of energizer to activator.

2. Layer 4 to 6 inches of dry, shredded leaves, dry garden trimmings and/or straw in the bottom of the composter. For easiest tumbling, avoid heavy materials like sod, clumps of wet grass, soil or fresh manure.

3. Sprinkle some of the Super Hot mixture on top of this first layer. Add a 2- to 3-inch layer of grass clippings, kitchen scraps and other nitrogen-rich materials. Sprinkle lightly with water. The correct moisture content is very important—the material should be moist (like a well-wrung sponge) but not wet.

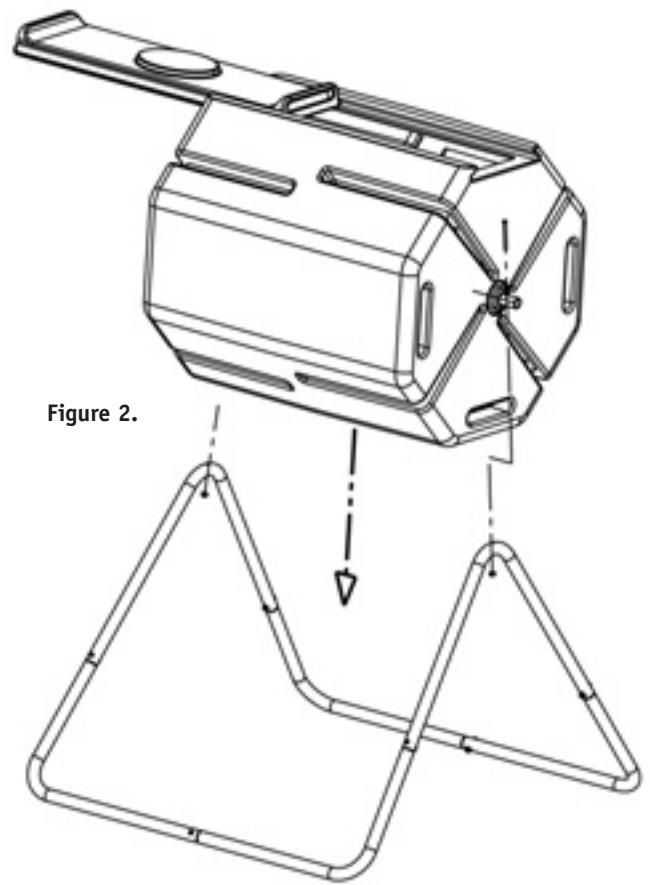

Figure 2.

4. Repeat the layering process described above, adding the Super Hot mixture to each layer until gone. Fill the composter to within 10 inches of the top, add water as needed to each layer.

“Tumble” the composter a few times to mix the ingredients. The molded ridges inside help break up materials and the air holes provide aeration.

Checking the Progress

After two or three days, check the temperature at the center of your mix with a compost thermometer or by touch. Temperatures between 120 and 160 degrees F indicate the beneficial organisms are multiplying and doing their job decomposing materials. Turning the composter 5 to 10 times every two or three days will mix the materials, incorporate fresh oxygen, and keep the process active.

If the compost is not heating up, check the moisture content to ensure materials are not drying out. This can happen quickly during the summer. Squeeze a handful of compost to see if it feels like a damp sponge. If it does, the water level is fine. If it feels dry, add a little more water (be careful not to add too much) and turn the composter to mix well. Continue turning the composter every two or three days.

Depending on the type of material you added, how finely it was shredded and other conditions such

as air temperature and moisture content, the compost should be ready in 4 to 8 weeks.

To remove the finished compost, slide off the cover, tip the composter and empty the contents through the opening. You may need to use a shovel or fork at first, then tip the unit over to empty it completely.

Finished compost will contain a mix of fine and coarse material. The compost can be sifted for use in potting mixes. Use the coarser compost as a nutritious top-dressing around outdoor plantings, put it directly into the garden, or add it to your next batch of compost.

For more information about the basic principles of composting, visit us online at www.gardeners.com.



Composting Tips

- Keep the moisture level damp, not soggy.
- Once the batch begins to heat up, turn the composter 5 to 10 times every few days to provide aeration.
- Use the composter on a level surface. If it's on an angle, a full batch can be very difficult to turn. If the composter is too heavy for you to move, consider making smaller batches, or get help turning the composter.
- If cold weather arrives before your batch has finished cooking, it may be left inside the Compost Tumbler until spring returns. To start it up again, add Super Hot or Energy Buttons (see *Ordering Information*) and some leaves, food scraps and grass clippings, and water as needed.
- Do not put meats, pet waste, fats, bones, fish, dairy products, trash or plastic into the Compost Tumbler. These do not break down easily and can attract rodents and other unwanted pests to your yard.

Ordering Information

#37-459Compost Tumbler
#02-175Super Hot Compost Starter
#07-219Energy Buttons, 5 Lbs.
#35-692 Compost Thermometer

To place an order, please call us or visit our web site for current prices.

PHONE ORDERS: 1-800-427-3363 CUSTOMER SERVICE: 1-800-876-5520
E-MAIL: info@gardeners.com WEB: www.gardeners.com