

Medium Garden Cart

Congratulations on your new Gardener's Supply Garden Cart! It features a foam-cushioned handle for a more comfortable grip and a front panel that easily slides out of your way when you dump the contents of the cart. We've applied a smooth, custom-bent aluminum trim so that edges won't catch debris or your clothing. With pre-drilled holes, your Garden Cart is easy to assemble and will give you many years of dependable service.

Parts List:	<i>Qty</i>	<i>Description</i>	<i>Qty</i>	<i>Description</i>
	(34)	T-Nuts	(1)	Handle
	(16)	1 $\frac{3}{8}$ " bolts	(1)	Leg stand
	(20)	$\frac{5}{8}$ " bolts	(1)	Steel Axle
	(4)	$\frac{1}{4}$ " x 20 lock nuts	(2)	20" Wheels
	(2)	$\frac{1}{2}$ " Axle Clamps	(1)	Bottom Panel
	(2)	Aluminum Angles	(2)	Side Panels
	(2)	2" x 2" Support Angles	(1)	Front Panel
	(2)	cotter pins	(5)	Panel Trim Pieces
			(1)	U-brace

- Tools Needed:**
- nail or awl
 - adjustable wrench
 - Phillips screwdriver
 - pliers

Helpful hint: During assembly, you may find it helpful to use a nail or awl to line up the holes when placing bolts. If you have difficulty assembling your cart, please contact us at: (info@gardeners.com or call 1-800-427-3363).

Safety Information

- Use caution on slopes. The cart does not have brakes and may roll away from you.
- Do not exceed the 400-pound load recommendation for this cart.
- Distribute weight evenly when loading the cart. Too much weight in the front of the cart can cause the cart to flip up unexpectedly and cause injury.

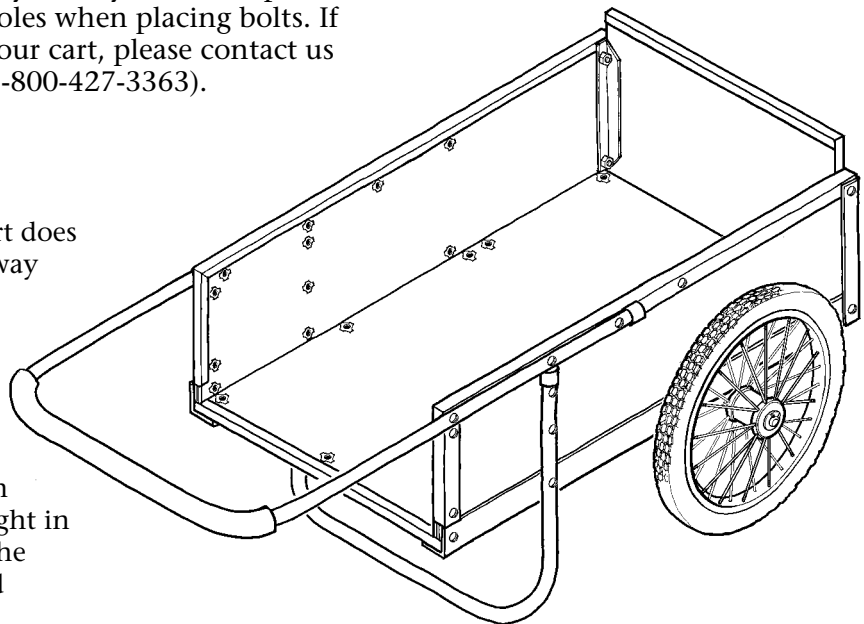

Assembly

T-Nut Installation:

Step 1. Lay out the wood panels on a hard level surface and arrange the hardware so it's easily accessible. **Note:** Each wood panel has pre-drilled holes and comes with one T-Nut already inserted into a hole. Lay out each wood panel as shown so that the sides with the installed T-Nut face up (Fig. 1). Also note that the Panel Trim and 2" x 2" Support Angles arrive already placed on their corresponding wood panels but not bolted into place. This will be done in a later step. For now, simply make sure all the Trim pieces fit flush around the edges of the cart Panels.

Step 2. Using a hammer, firmly tap a T-Nut into each of the pre-drilled holes in the wood panels until the head of the T-Nut rests flush with the surface of the wood. Do not place a T-Nut in the holes marked "No T-Nut" (See Fig. 1).

NOTE: If for any reason you need to remove a T-Nut, insert a 1 $\frac{3}{8}$ " bolt into the T-Nut from the opposite side and strike it with a hammer to knock it out of the wood panel and start over.

Attaching the Trim and Support Angles:

Step 3. Start with the Bottom Panel. *The corners of the front and back Trim pieces should be sandwiched between the Bottom Panel and the 2"x2" Support Angles (fig. 2).* Make sure the holes in the front and back Trim and the Support Angles are lined up with the pre-drilled holes in the Bottom Panel (Fig. 2). Insert four 5/8" Bolts up through the underside to connect the Trim and Support Angles to the Bottom Panel. **Tip:** You may find it helpful to use a nail or an awl to line up the holes when inserting the bolts into the T-Nuts. We've included extra $\frac{5}{8}$ " Bolts and T-Nuts in case any are stripped during the assembly.

Step 4. Attach the Front Panel Trim to the Front Panel using two $\frac{5}{8}$ " Bolts (Fig 1).

Cart Assembly:

Step 5. Position the Left and Right Panels inside the 2"x2" Support Angles of the Bottom Panel, making sure the sides of the Panels with T-Nuts face inward and the wide side of the aluminum trim on both Panels faces out. **Do not attach the Trim to the top of the Left and Right Panels at this time.** This Trim will be attached later in conjunction with other parts.

Using the $\frac{5}{8}$ " bolts, attach each Side Panel to the 2"x2" Support Angles by placing a bolt through holes A and C from the outside. Tighten the bolts on each side (Fig. 2).

Fig. 1

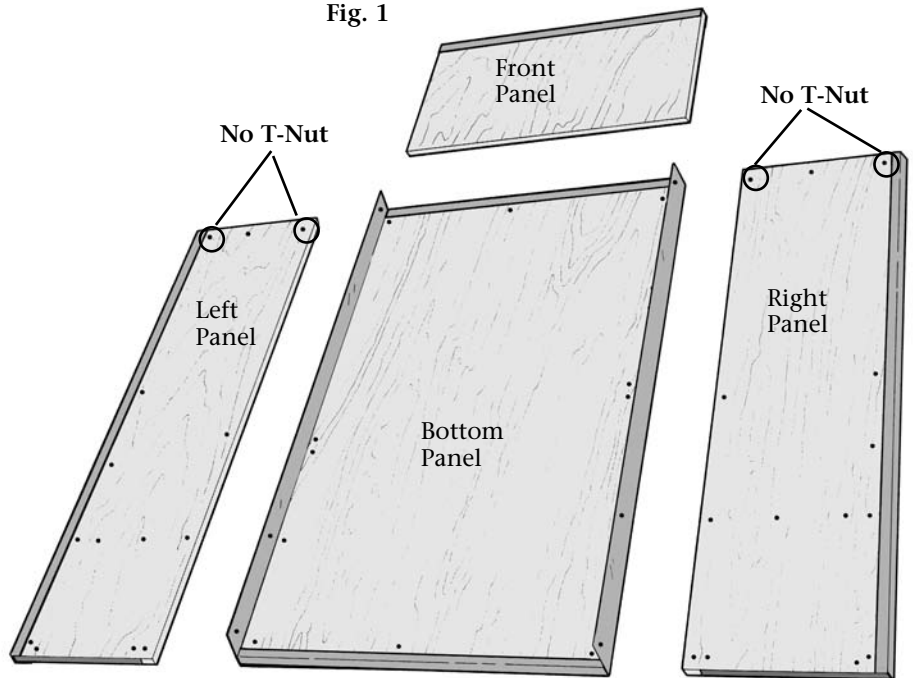

Step 6. Place the welded U-brace on the front end of the cart panels (Fig. 3). Do not use bolts to attach the U-brace until Step 7.

Step 7. Place an Aluminum Angle inside each corner of the U-brace with the cut of each angle sloping inward as shown in Fig. 4. From the outside, align the top and bottom holes in the U-brace with the holes of the Side Panels and Aluminum Angles.

Insert two 1 $\frac{3}{8}$ " bolts into each side (four total) from the outside. Using a wrench and Phillips screwdriver, firmly tighten the bolts on the inside with a lock nut (Fig. 4). The U-brace and Aluminum Angles provide a channel for the Front Panel to slide up and down.

Step 8. Place the Front Panel in the channel to make sure the Panel opens and closes freely (Fig. 5). Adjust the Aluminum Angles if necessary. Remove the Front Panel.

Step 9. Turn the cart body upside down. Put one end of the Axle through a Wheel hub (Fig. 6). Insert a cotter pin through the small hole in the Axle that is located on the outside of the Wheel hub. Use pliers to spread the ends of the pin apart to form a "Y" around the end of the Axle.

Slide the second Wheel onto the other end of the Axle. Insert a Cotter Pin and spread the ends of the Pin apart to form a "Y." Adjust the Axle so that the Wheels line up evenly on both sides of the Bottom Panel. Fasten the Axle to the Bottom Panel using the Axle Clamps and two $\frac{5}{8}$ " bolts per Clamp (Fig. 6).

Step 10. Attach the Leg Stand to the Side Panels using the 1 $\frac{3}{8}$ " bolts. Insert the bolts into the three holes on each side of the Leg Stand (Fig. 7). Alternate from side to side as you tighten each bolt. Turn the cart upright to rest on the Wheels and Leg Stand.

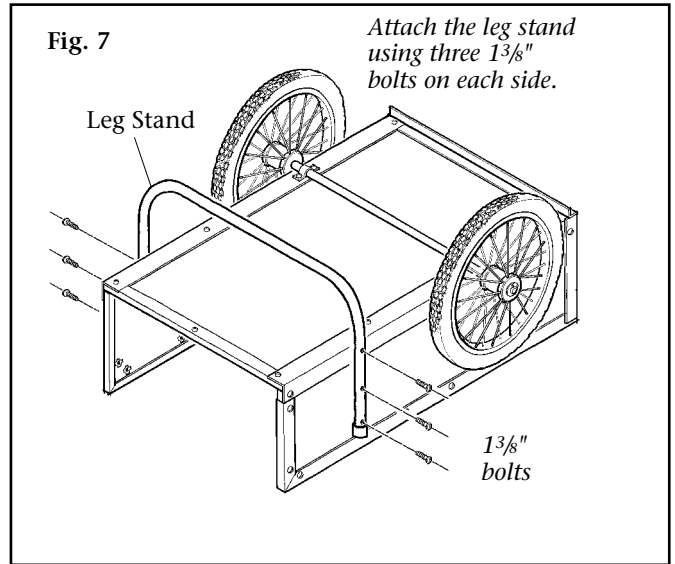
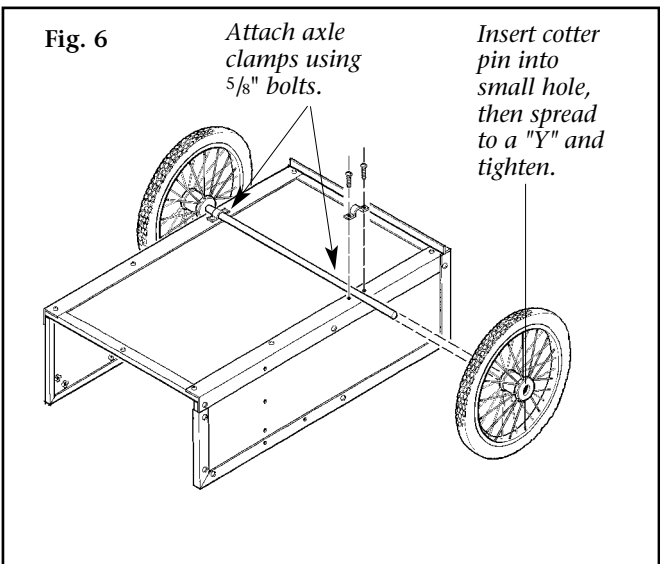
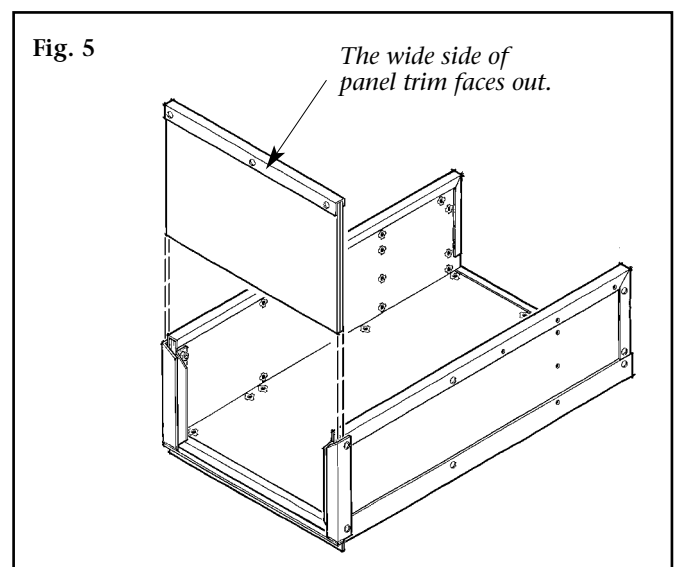
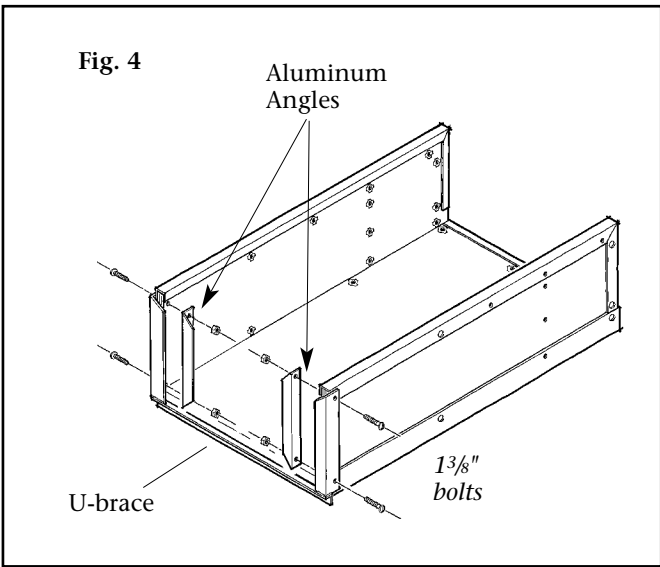
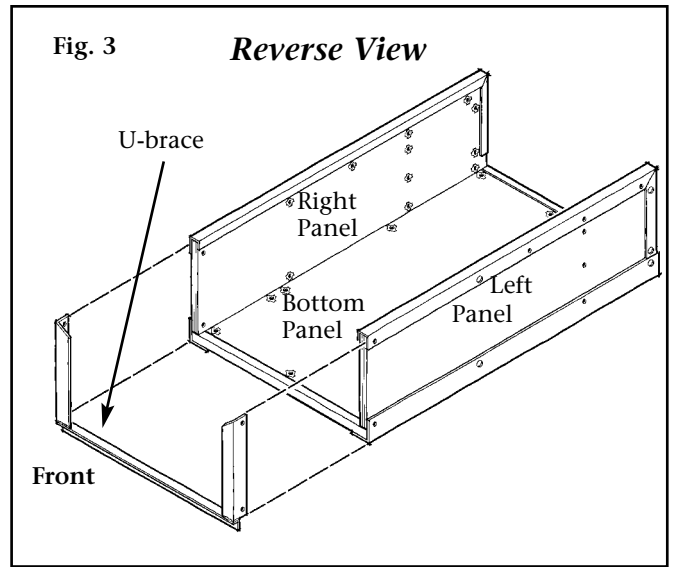
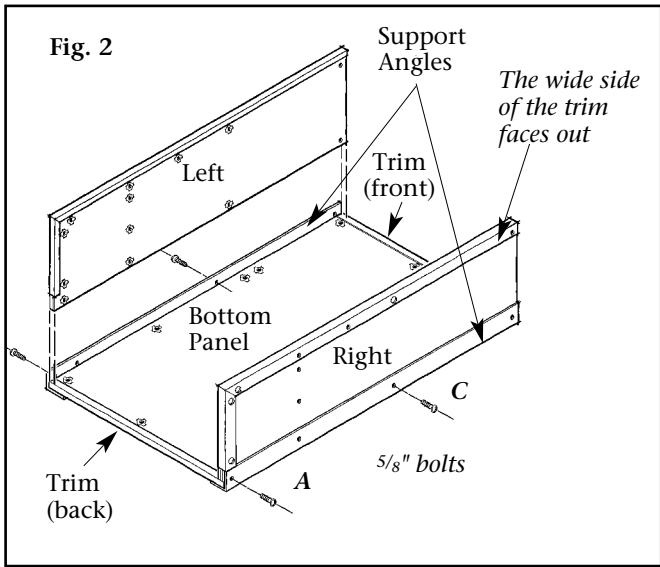

Step 11. Attach the Handle to the Side Panels using the 1³/₈" bolts. Insert the bolts into the three holes on each side of the Handle (Fig. 8) and tighten. You may adjust the length of the Handle at this time.

To make it shorter, simply push the Handle forward and attach it to the Side Panels using only two bolt holes on each side. Congratulations! You've finished the assembly.

Garden Cart Maintenance

- Protect your cart from harsh weather by storing it in a shed, garage, or under a tarp to extend the life of the plywood. Be sure to clean out debris with a broom and allow the cart to dry in sunlight.
- To keep the cart in proper working condition, tighten the nuts and bolts periodically.
- To extend the life of the plywood, repaint or stain it every two years. We recommend a non-toxic, natural stain that will not contaminate compost, soil or other garden materials you may carry in the cart.

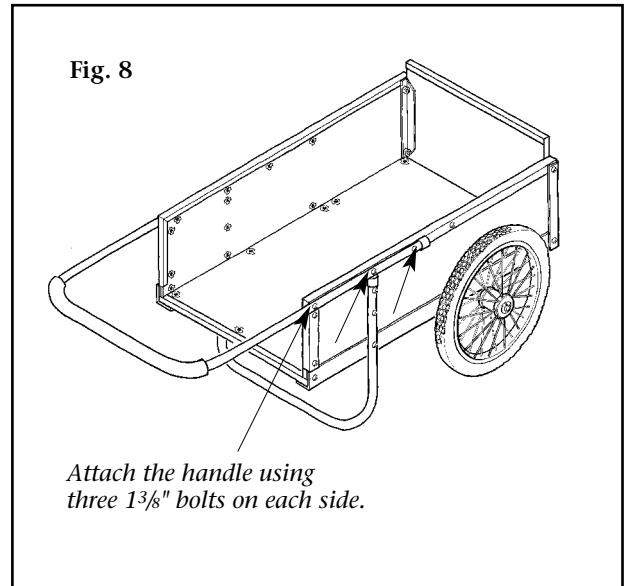

Ordering Information

- #36-499 Gardener's Supply Cart, Medium
- #36-500 Gardener's Supply Cart, Large

To place an order, please call us or visit our web site for current prices.

128 Intervale Road, Burlington, Vermont 05401
phone orders: 1-800-427-3363 customer service: 800-876-5520 fax: 800-551-6712
e-mail: info@gardeners.com web: www.gardeners.com